



US 20250164203A1

(19) **United States**

(12) **Patent Application Publication**  
**McDonald**

(10) **Pub. No.: US 2025/0164203 A1**

(43) **Pub. Date: May 22, 2025**

(54) **FIREARM SAFETY WITH SEAR BLOCK**

(52) **U.S. Cl.**

CPC ..... *F41A 17/56* (2013.01); *F41C 3/00* (2013.01)

(71) Applicant: **Brian McDonald**, Maynard, MA (US)

(72) Inventor: **Brian McDonald**, Maynard, MA (US)

(57)

**ABSTRACT**

(21) Appl. No.: **18/650,917**

A pistol comprising a frame; a striker connected to the frame and movable between a rearward energized position and a forward striking position; a trigger; a sear responsive to the trigger and operable to restrain the striker in the rearward position and release the striker to the forward position; a safety element movable between a live condition in which trigger motion to release of the striker is enabled and a safe condition in which trigger motion to release of the striker is disabled; and the safety element including a secondary safety surface operably engaging the sear to maintain the sear in a retraining position when the safety element is in the safe condition.

(22) Filed: **Apr. 30, 2024**

**Related U.S. Application Data**

(60) Provisional application No. 63/463,404, filed on May 2, 2023.

**Publication Classification**

(51) **Int. Cl.**

*F41A 17/56* (2006.01)

*F41C 3/00* (2006.01)

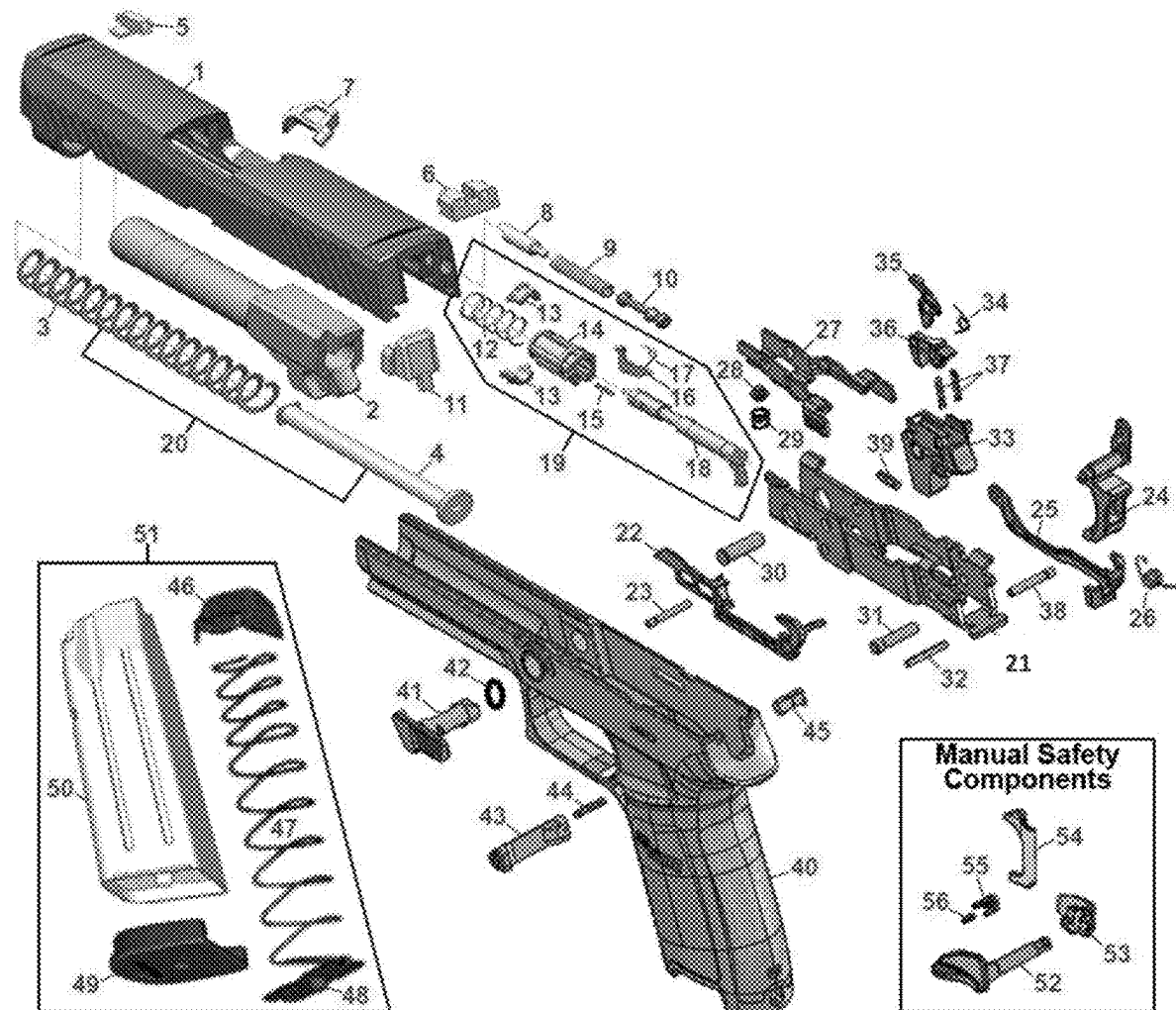

Figure 1

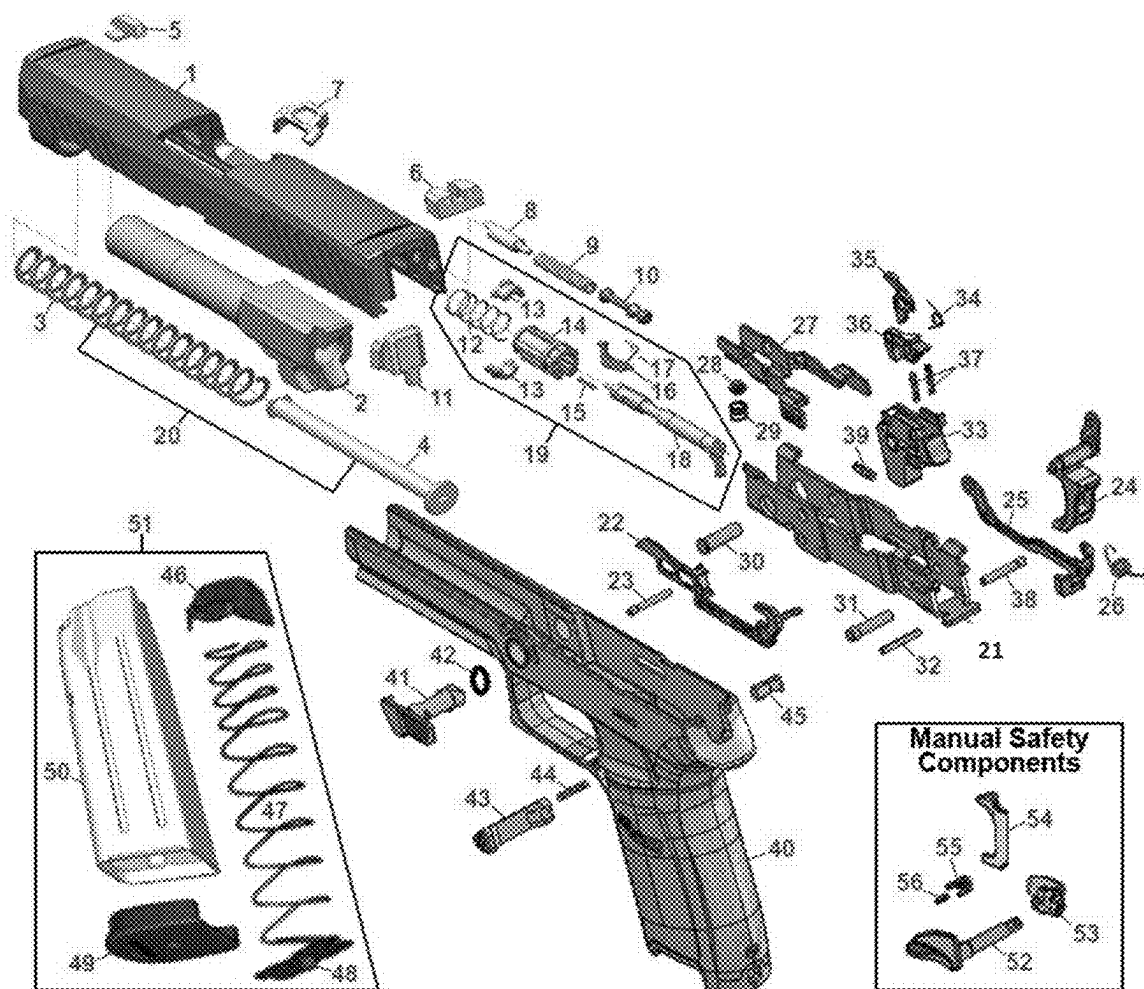
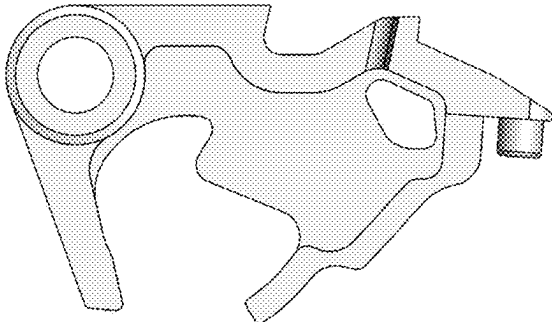

Figure 2

- |                              |                                   |
|------------------------------|-----------------------------------|
| 1. Slide                     | 30. Slide Catch Lever Pin         |
| 2. Barrel                    | 31. Safety Lever Pin              |
| 3. Recoil Spring             | 32. Coiled Pin 2.5x20mm           |
| 4. Recoil Spring Guide Rod   | 33. Sear Housing                  |
| 5. Front Sight               | 34. Safety Lever Spring           |
| 6. Rear Sight                | 35. Safety Lever                  |
| 7. Extractor                 | 36. Sear                          |
| 8. Extractor Pin             | 37. Sear Spring                   |
| 9. Extractor Spring          | 38. Sear Housing Pin              |
| 10. Extractor Spring Pin     | 39. Take Down Safety Lever Spring |
| 11. Slide Cap                | 40. Grip Module                   |
| 12. Striker Spring           | 41. Take Down Lever               |
| 13. Striker Spring Cup       | 42. Take Down Lever O-Ring        |
| 14. Striker Housing          | 43. Magazine Release              |
| 15. Striker Return Spring    | 44. Magazine Release Spring       |
| 16. Striker Safety           | 45. Magazine Stop                 |
| 17. Striker Safety Spring    | 46. Follower                      |
| 18. Striker                  | 47. Magazine Spring               |
| 19. Striker Assembly         | 48. Magazine Spring Retainer      |
| 20. Recoil Spring Assembly   | 49. Magazine Baseplate            |
| 21. Serialized Chassis       | 50. Magazine Body                 |
| 22. Take Down Safety Lever   | 51. Magazine Assembly             |
| 23. Trigger Stop Pin         | 52. Left Manual Safety Lever      |
| 24. Trigger                  | 53. Right Manual Safety Lever     |
| 25. Trigger Bar              | 54. Disconnecter                  |
| 26. Trigger Bar Spring       | 55. Manual Safety Detent          |
| 27. Slide Catch Lever        | 56. Manual Safety Detent Spring   |
| 28. Slide Catch Lever Post   |                                   |
| 29. Slide Catch Lever Spring |                                   |

Figure 3

Improved



Prior Art

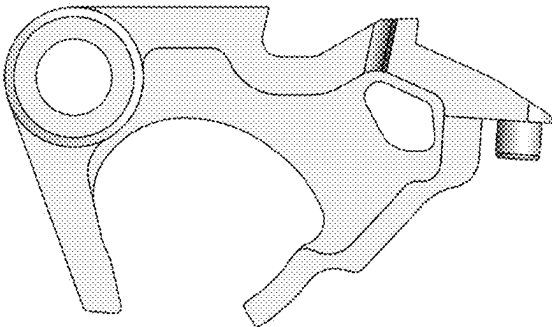
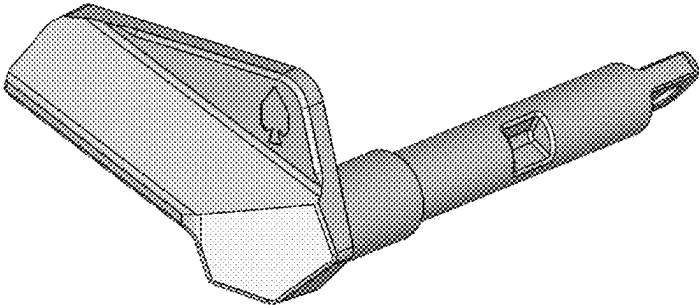

Figure 4

Improved



Prior Art

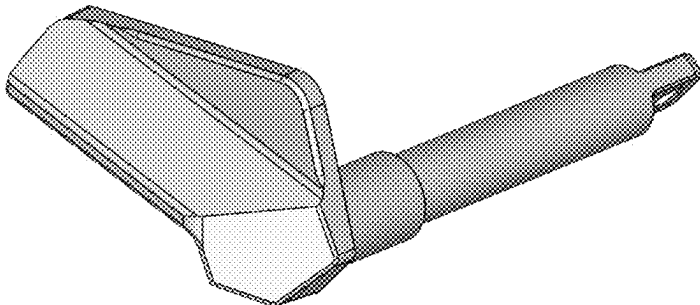

Figure 5 – Prior Art

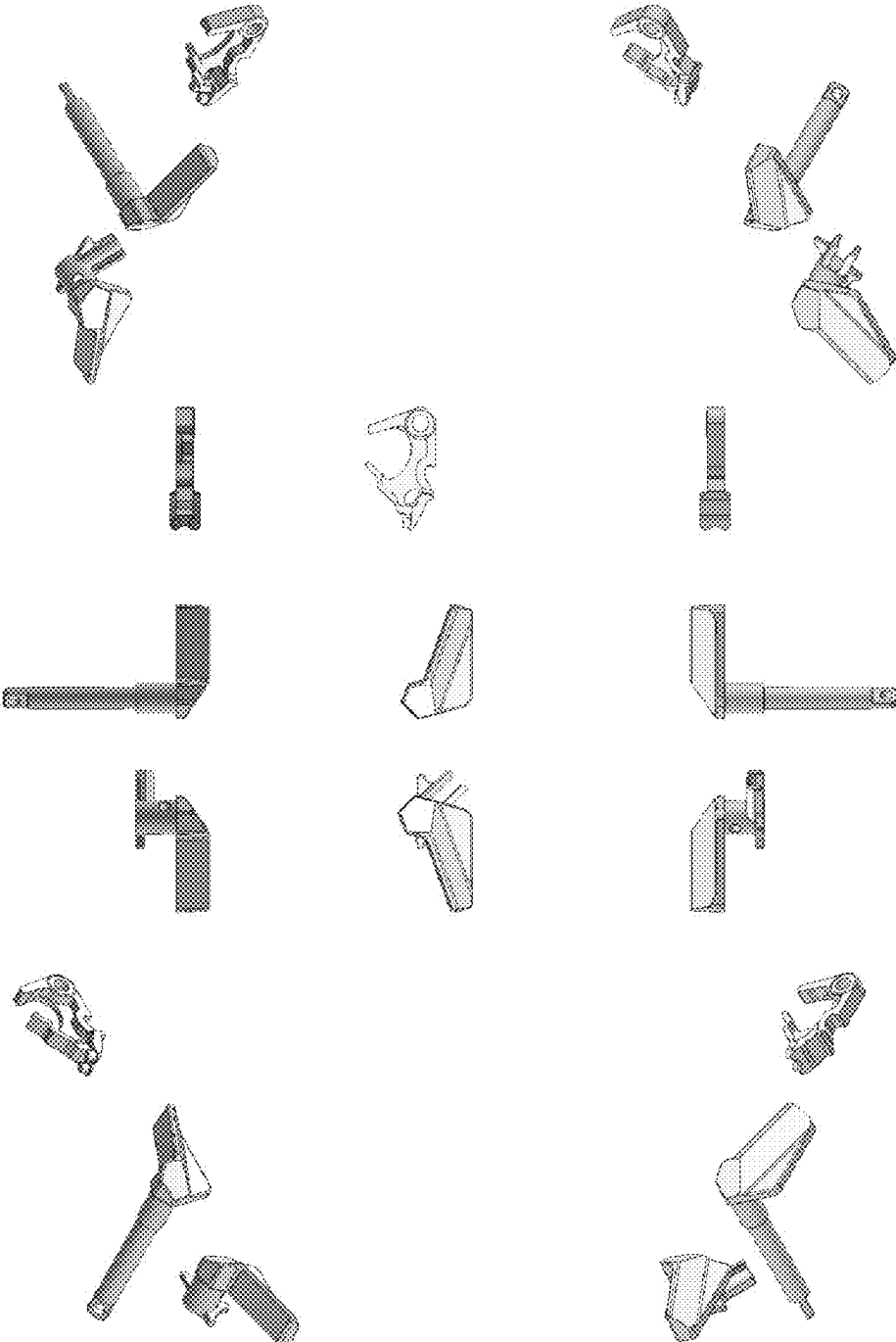

Figure 6 – Improved Design

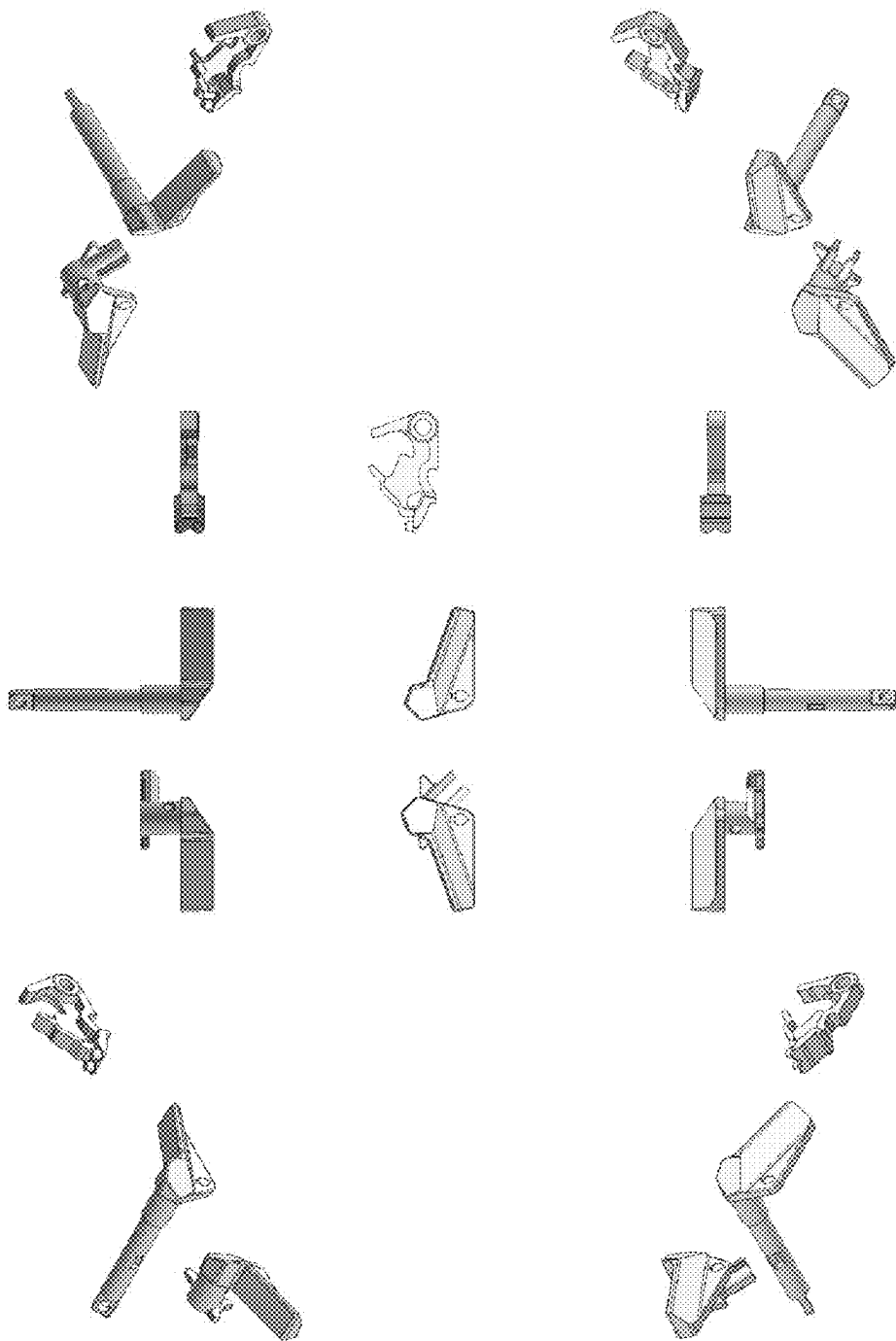

Figure 7

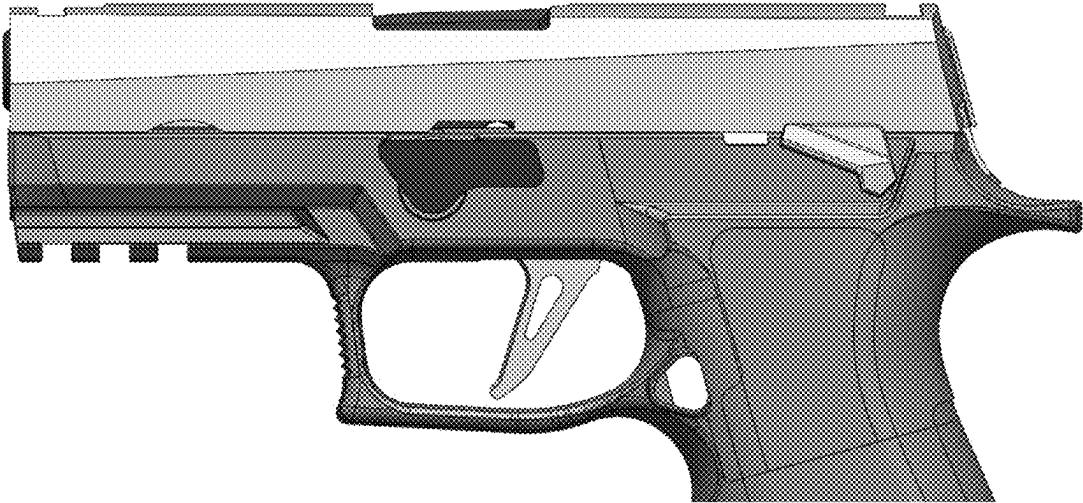

Figure 8

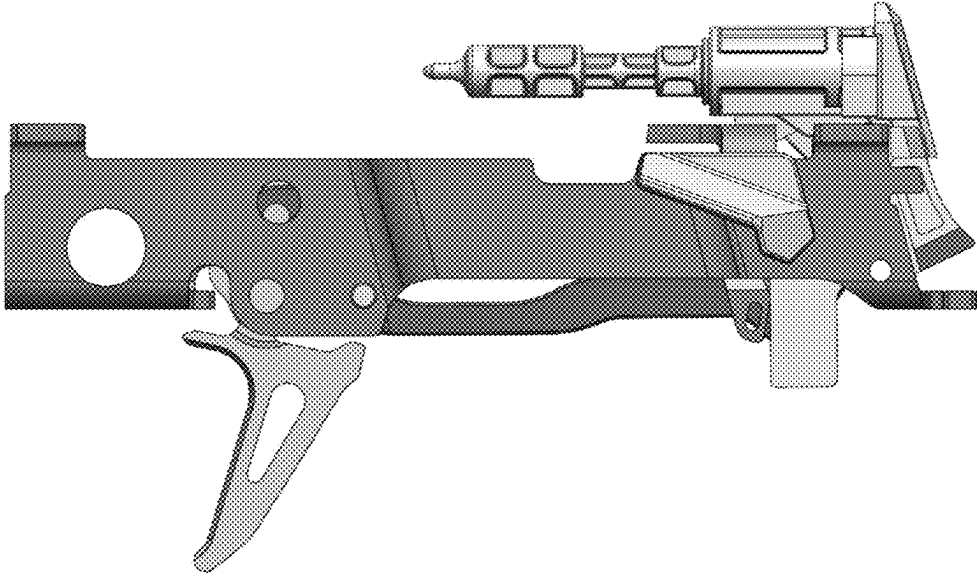

Figure 9

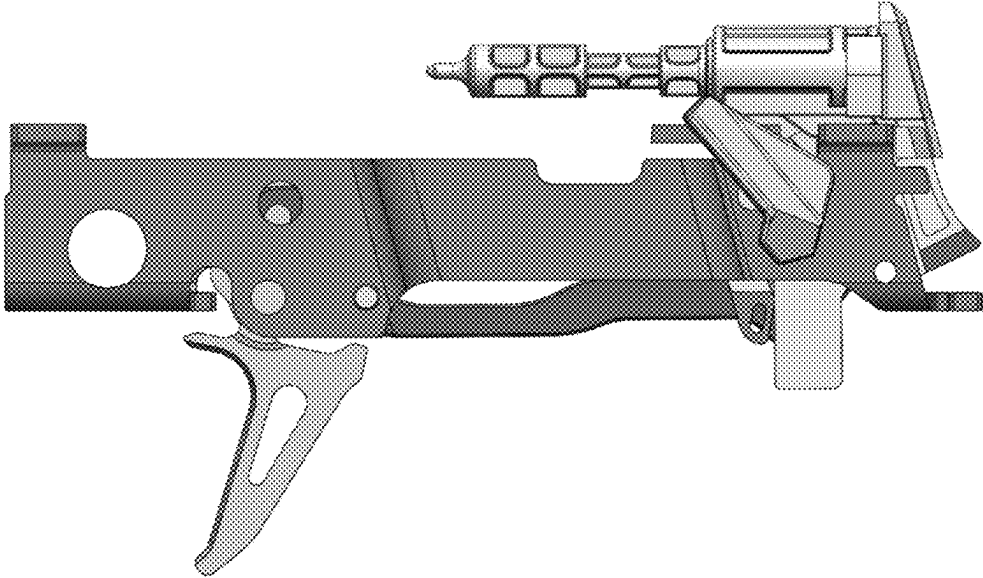

Figure 10

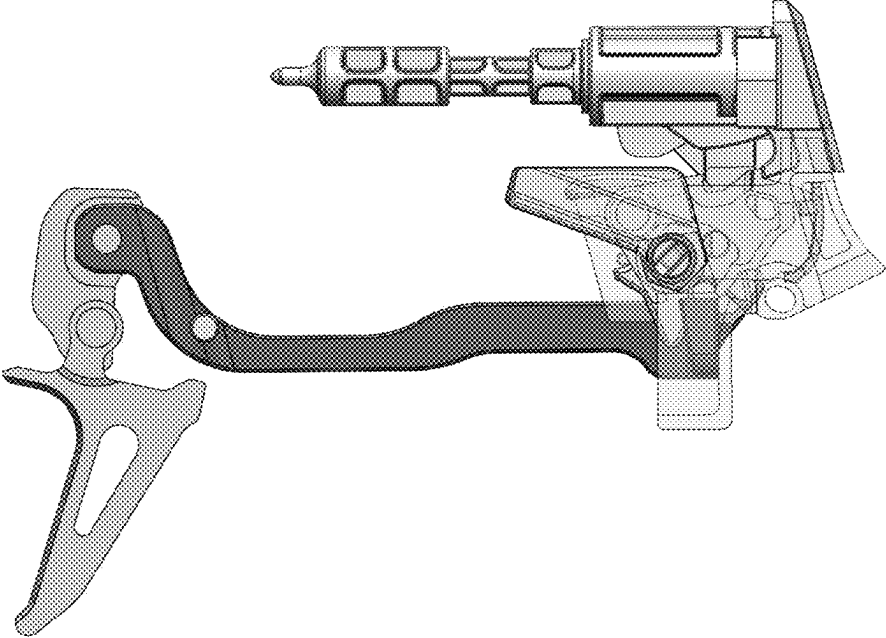

Figure 11

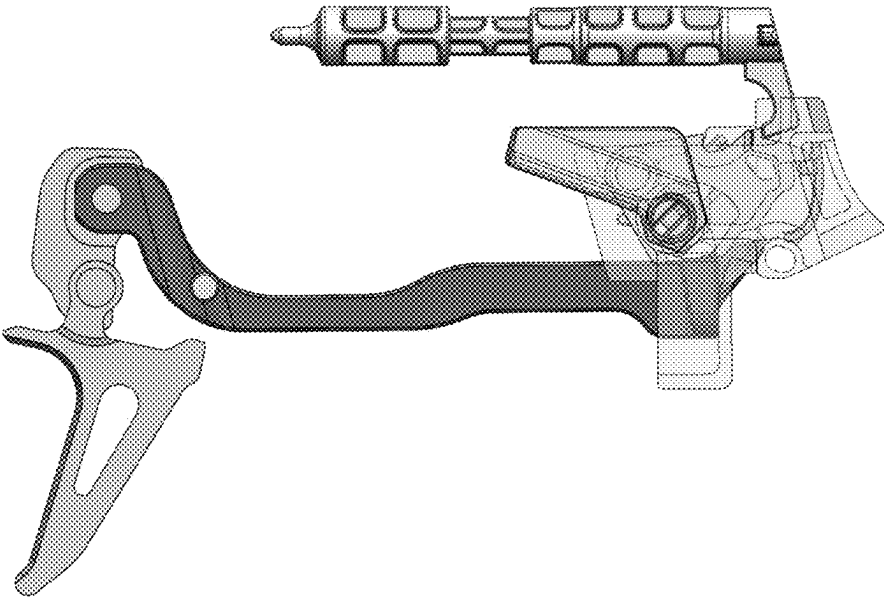

Figure 12

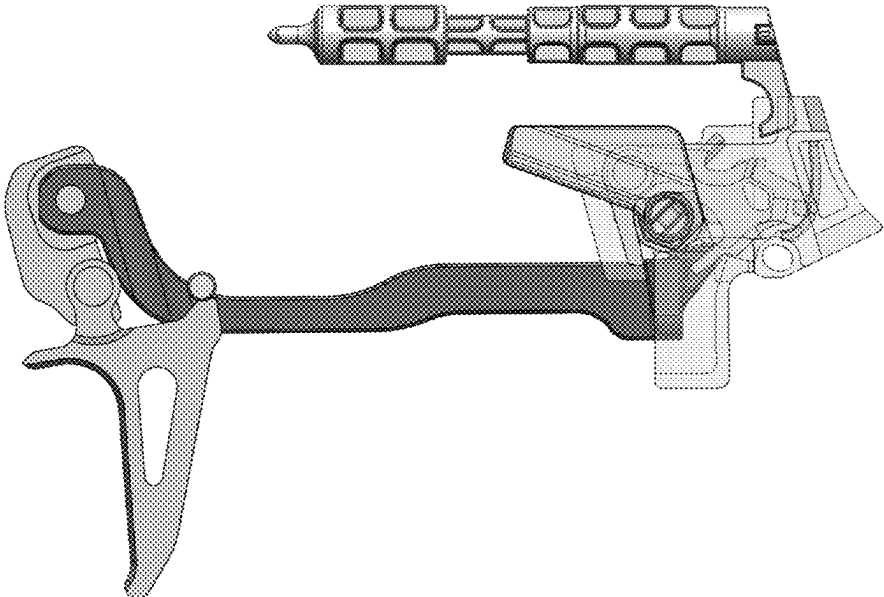

Figure 13

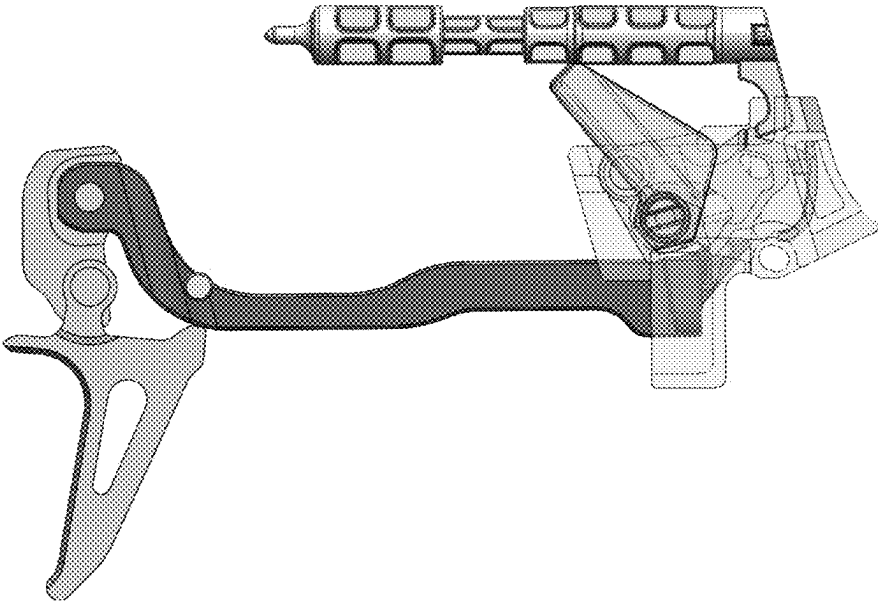

Figure 14

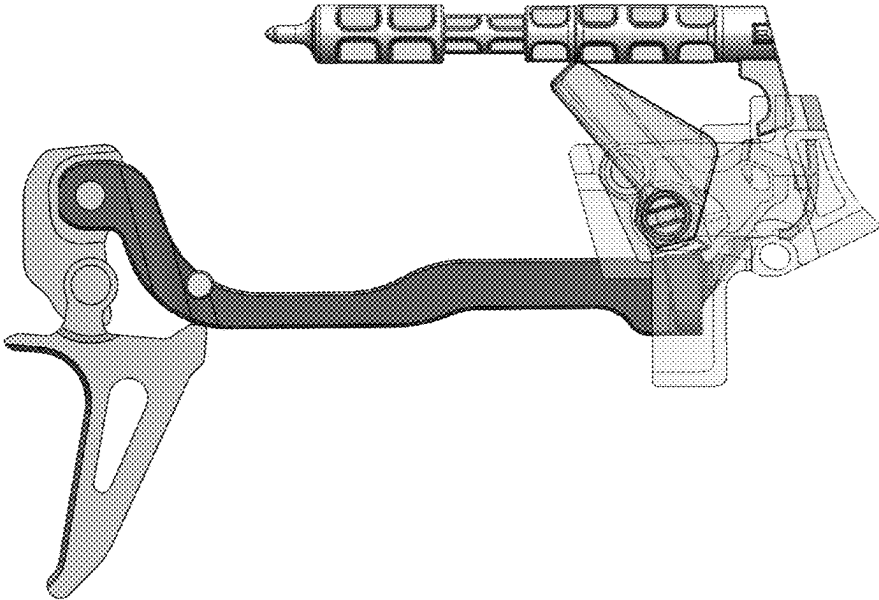

Figure 15

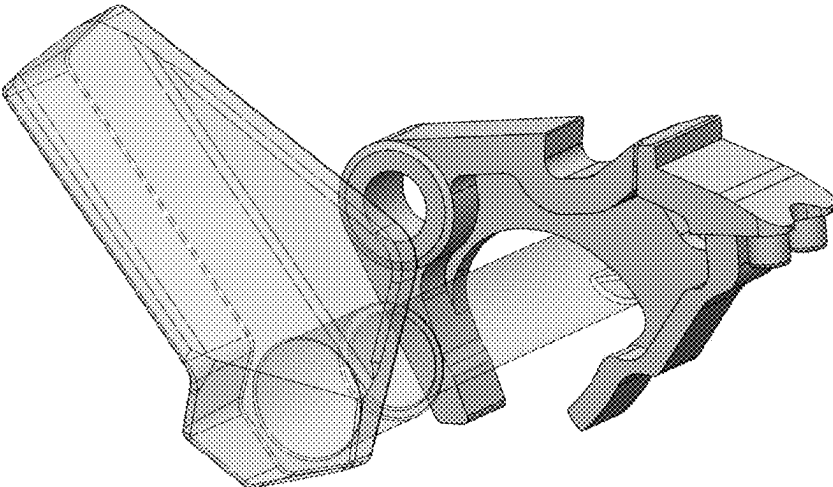

Figure 16

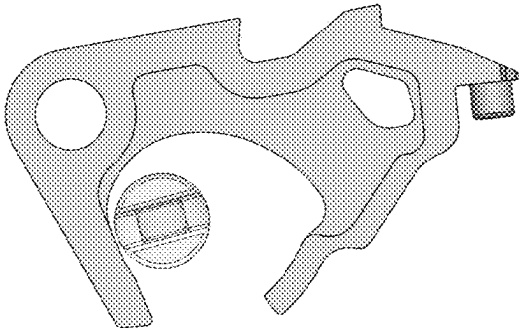

Figure 17

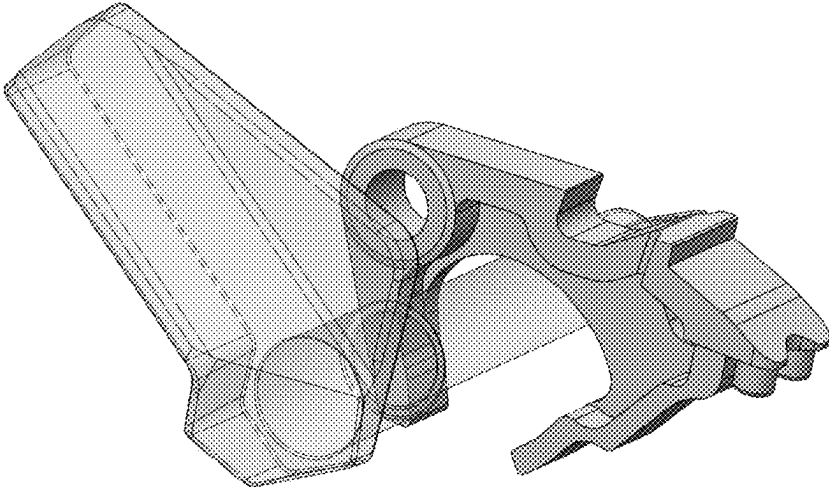

Figure 18

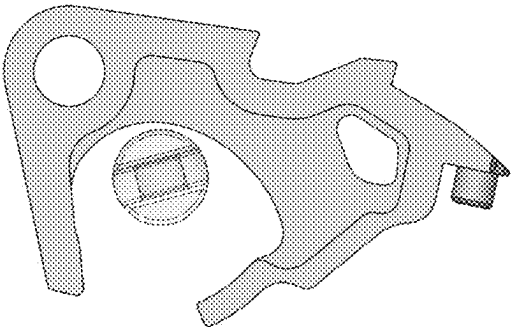

Figure 19

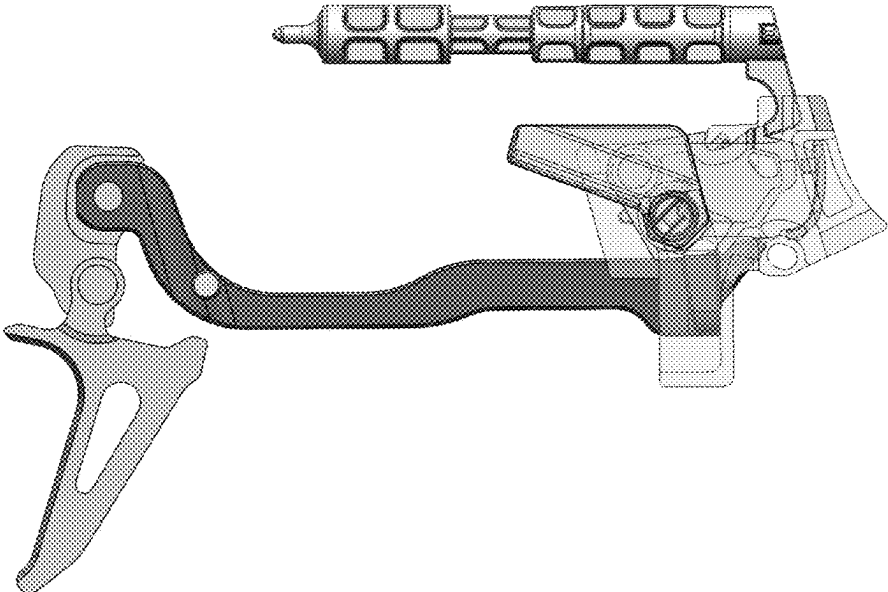

Figure 20

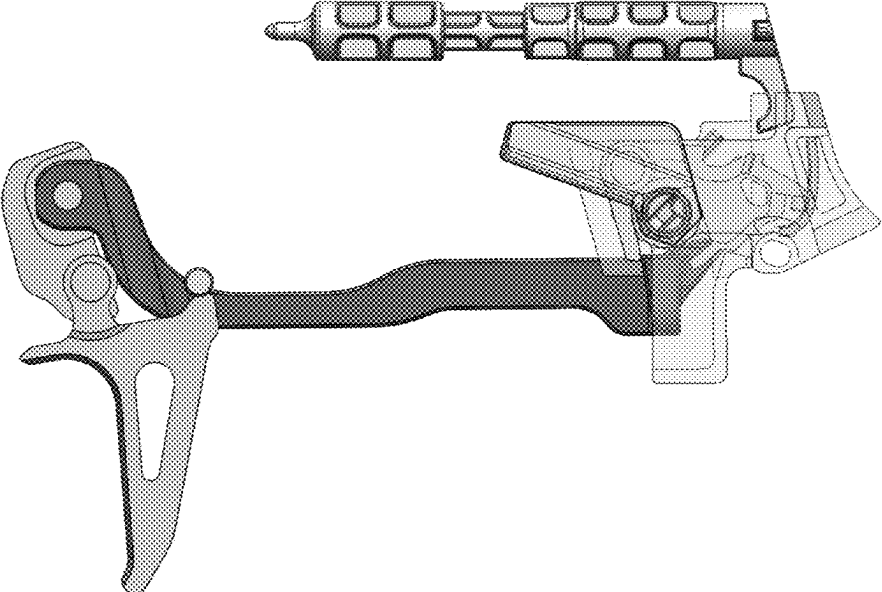

Figure 21

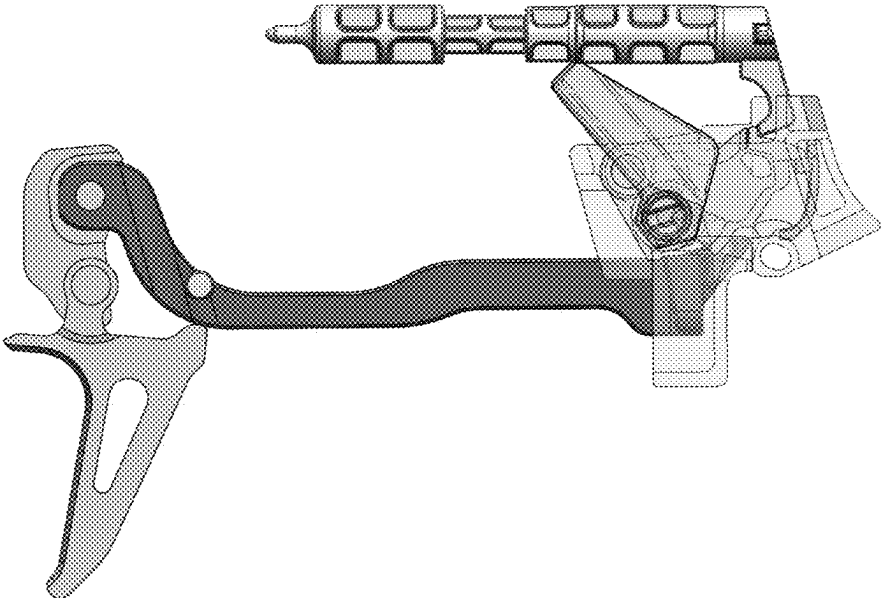

Figure 22

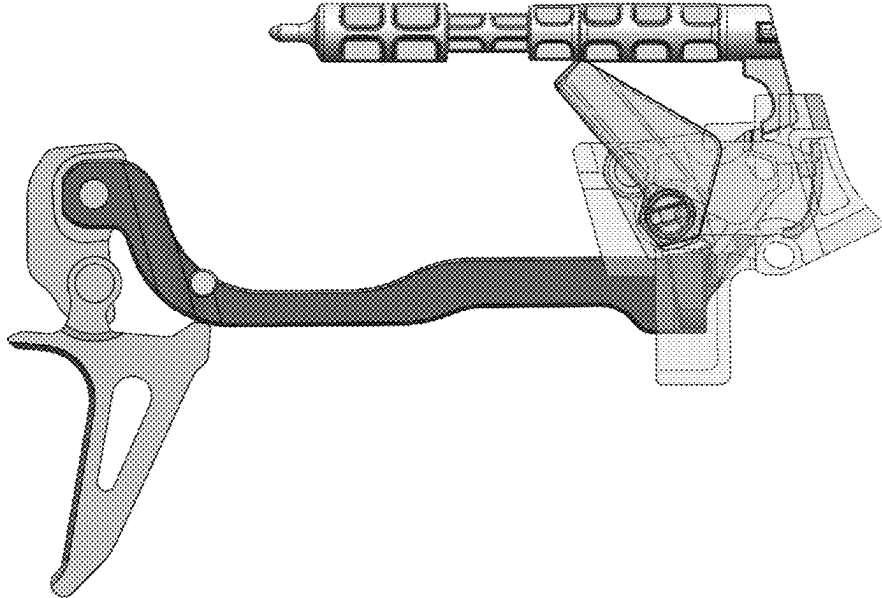

Figure 23

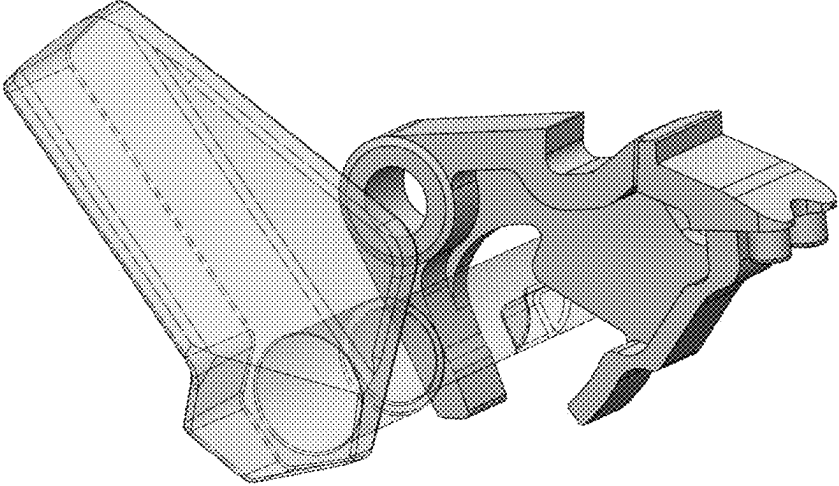

Figure 24

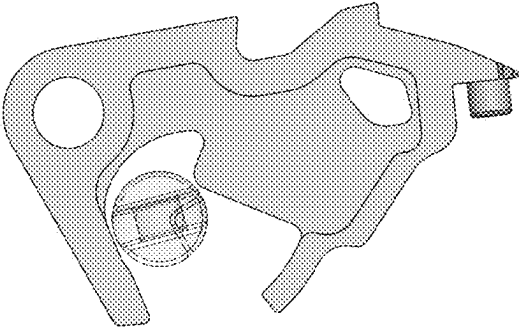

Figure 25

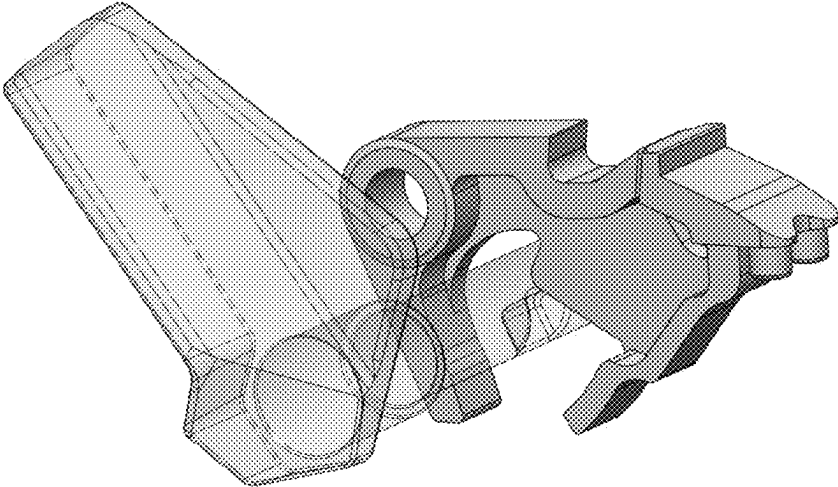
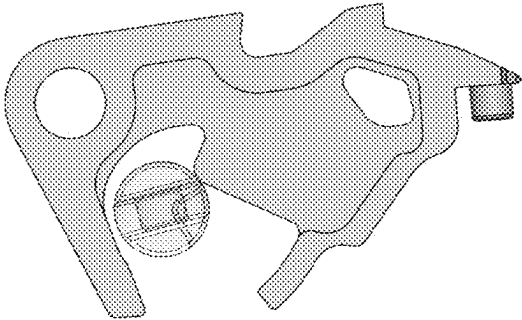

Figure 26



**FIREARM SAFETY WITH SEAR BLOCK**

**CROSS-REFERENCE TO RELATED APPLICATIONS**

[0001] This application claims the benefit of U.S. Provisional Patent Application No. 63/463,404, filed on May 2, 2023, entitled “FIREARM SAFETY WITH SEAR BLOCK”, which is hereby incorporated by reference in its entirety for all that is taught and disclosed therein.

**FIELD OF THE INVENTION**

[0002] The present invention relates to sear blocks for firearms.

**BACKGROUND AND SUMMARY**

[0003] The manual safety version of the popular P320 firearm which is currently being sold to the civilian, law enforcement and military markets features a safety mechanism which mechanically blocks the trigger bar from moving.

[0004] This keeps the trigger from being pulled while the safety lever is in the “safe” position. While this will prevent the trigger bar from moving forward and acting upon the sear to release the firing pin but it does not, in any way, prevent the sear itself from moving under the force from any other action

[0005] The above disadvantage is addressed by a pistol comprising a frame; a striker connected to the frame and movable between a rearward energized position and a forward striking position; a trigger; a sear responsive to the trigger and operable to restrain the striker in the rearward position and release the striker to the forward position; a safety element movable between a live condition in which trigger motion to release of the striker is enabled and a safe condition in which trigger motion to release of the striker is disabled; and the safety element including a secondary safety surface operably engaging the sear to maintain the sear in a retraining position when the safety element is in the safe condition.

**BRIEF DESCRIPTION OF THE DRAWINGS**

[0006] FIG. 1 shows an exploded view of the prior art configuration of the Sig Sauer P320.

[0007] FIG. 2 provides descriptions for the prior art components depicted in FIG. 1.

[0008] FIG. 3 depicts a left side view of the prior art and improved sears.

[0009] FIG. 4 depicts an isometric view of the prior art and improved left side safeties.

[0010] FIG. 5 depicts multiple views of the prior art sear and safety levers.

[0011] FIG. 6 depicts multiple views of the improved sear and safety levers.

[0012] FIG. 7 depicts the prior art assembly from a side view in the fire position.

[0013] FIG. 8 depicts the prior art assembly from a side view in the fire position without the slide, grip, takedown lever and barrel.

[0014] FIG. 9 depicts the prior art assembly from a side view in the safe position without the slide, grip, takedown lever and barrel.

[0015] FIG. 10 depicts the prior art assembly from a side view in the fire position with the chassis removed.

[0016] FIG. 11 depicts the prior art assembly from a side view in the fire position with the striker safety and slide rear cap removed.

[0017] FIG. 12 depicts the prior art assembly from a side view in the fire position with the trigger at the extent of its full travel limit.

[0018] FIG. 13 depicts the prior art assembly from a side view in the safe position with the trigger pulled and stopped against the safety notch.

[0019] FIG. 14 depicts the prior art assembly from a side view in the safe position with the trigger pulled and stopped against the safety notch and the sear rotated downward beyond the point of release of the striker.

[0020] FIG. 15 depicts the prior art sear and safety in an isometric view in the safe position with the sear in the upward reset position.

[0021] FIG. 16 depicts the prior art sear and safety in a cross sectional side view in the safe position with the sear in the upward reset position.

[0022] FIG. 17 depicts the prior art sear and safety in an isometric view in the safe position with the sear rotated downward beyond the point of release of the striker.

[0023] FIG. 18 depicts the prior art sear and safety in a cross sectional side view in the safe position with the sear rotated downward beyond the point of release of the striker.

[0024] FIG. 19 depicts the improved design from a side view in the fire position.

[0025] FIG. 20 depicts the improved design from a side view in the fire position with the trigger at the extent of its full travel limit.

[0026] FIG. 21 depicts the improved design from a side view in the safe position with the trigger pulled and stopped against the safety notch.

[0027] FIG. 22 depicts the improved design from a side view in the safe position with the trigger pulled and stopped against the safety notch and the sear rotated downward until it contacts the safety pivot bar where the striker cannot be released.

[0028] FIG. 23 depicts the improved sear and safety in an isometric view in the safe position with the sear in the upward reset position.

[0029] FIG. 24 depicts the improved sear and safety in a cross sectional side view in the safe position with the sear in the upward reset position.

[0030] FIG. 25 depicts the improved sear and safety in an isometric view in the safe position with the sear in the downward stop position against the safety pivot bar where the striker cannot be released.

[0031] FIG. 26 depicts the improved sear and safety in a cross sectional side view in the safe position with the sear in the downward stop position against the safety pivot bar where the striker cannot be released.

**DETAILED DESCRIPTION OF A PREFERRED EMBODIMENT**

[0032] The manual safety version of the popular P320 firearm which is currently being sold to the civilian, law enforcement and military markets features a safety mechanism which mechanically blocks the trigger bar from moving, and therefore the trigger from being pulled, while the safety lever is in the “safe” position. (FIG. 3) The sear on the P320 firearm will rotate between two positions about a pivot pin on which it is mounted. The first position, described here as the “reset” position (FIG. 2) is the position where the rear

portion of the sear is rotated upward to hold the firing pin back. The sear has two springs acting upon the rearward end of the sear which bias the sear to be held in this position. The second position, described here as the "release" position, is the position where the rearward portion of the sear has been acted upon to be lowered which will release the firing pin, allowing it to travel past the sear and impact the primer of a loaded round already positioned in the barrel of the firearm.

[0033] The prior art "safety" mechanism will prevent the trigger bar from moving forward and acting upon the sear to release the firing pin but it does not, in any way, prevent the sear itself from moving under the force from any other action. This allows for the potential for the sear to be jarred and moved from the reset position to the release position even when the firearm safety is in the "safe" position. This condition is clearly shown in FIG. 14. This allowed rotational movement of the sear will then release the firing pin. When this occurs, the firing pin will be free to travel forward with only a firing pin safety featuring minimal contact area remaining in place to prevent the firing pin from striking the primer of a loaded round already positioned in the barrel of the firearm. In this way, the prior art is an incomplete and unsafe design. This is further evidenced by multiple lawsuits which have been filed alleging that the P320 model firearm will have accidental discharges even when securely stored in a holster with no action being taken to manipulate the trigger, safety or any other component of the firearm.

[0034] As a means to improve the safety of the firearm platform, the present invention describes a backward compatible, drop in "kit" which will replace the factory installed safety lever and sear with improved components. (FIG. 6) Installation of the "kit" will require no modifications to any other internal or external components and will dramatically improve the safety of the platform.

[0035] The improved safety lever assembly will come with a left and a right side safety lever. The left side safety lever will feature a notch precisely placed on the rotational pivot pin and timed with the rotational position of the lever itself. The improved sear has an additional element when compared to the prior art sear which, with the safety in the "fire" position, will travel into the "notch" on the safety lever pivot pin. The additional element on the sear will make contact with the outer diameter of the safety lever pivot bar when the safety is in the "safe" position. Upon making contact with the safety lever pivot bar, the rotational movement of the sear will be stopped. In this stopped position, the sear will remain in contact with the firing pin and prevent the firing pin from travelling forward and being able to strike the primer of a loaded round already position in the barrel of the

firearm. In summary, the improved sear has an additional element which interferes with the profile of the safety lever pivot pin when the safety lever is in the "safe" position, thereby preventing the sear from moving to the "release" position and allowing the firing pin to travel forward.

[0036] A further embodiment of the kit is one which can be installed into a firearm which was originally manufactured in a non-manual safety configuration. This upgrade will require machining of the serialized chassis and the grip module and will include a manual safety compatible trigger bar, right and left side manual safety levers, manual safety detent and manual safety detent spring. After installation by a qualified gunsmith, the full conversion kit will provide the same improved safety features as previously described in the upgrade "kit".

[0037] An additional configuration of the safety lever and sear element to create interference and prevent release of the firing pin when the safety lever is in the "safe" position is also disclosed where a protruding element is added to the safety lever. This protruding element, rather than a "notch" as previously described would be rotated into a position which would interfere with the rotational movement of the sear. This interference will prevent the sear from moving to the "release" position when the safety lever is in the "safe" position as previously described. This protruding element would be installed through an enlarged hole on one side of the serialized chassis and sear housing or would be attached to the safety lever pivot pin after the safety lever is positioned in the serialized chassis. This configuration is not preferred due to the extensive modification to the host firearm required for this embodiment of the design.

I claim:

1. A pistol comprising:

- a frame;
- a striker connected to the frame and movable between a rearward energized position and a forwarded striking position;
- a trigger;
- a sear responsive to the trigger and operable to restrain the striker in the rearward position and release the striker to the forward position;
- a safety element movable between a live condition in which trigger motion to release of the striker is enabled and a safe condition in which trigger motion to release of the striker is disabled; and
- the safety element including a secondary safety surface operably engaging the sear to maintain the sear in a retraining position when the safety element is in the safe condition.

\* \* \* \* \*